

## JASPER ELECTRONICS

1580 North Kellogg Drive

Anaheim, Calif. 92807

Phone: (714) 917-0749

Fax: (714) 917-0786

Email: [sales@jasperelectronics.com](mailto:sales@jasperelectronics.com)

Web: [www.jasperelectronics.com](http://www.jasperelectronics.com)

# **HML801 MODEL SERIES**

***12V, 650W and 24V - 54V, 800 WATT SINGLE OUTPUT***

### **Features:**

- Front End Power Supplies – 12V through 54V.
- >0.99 line Power Factor Corrected typical at AC 115V.
- High Density.
- Hot Swap-Redundancy.
- Module for 19 Inch Rack (1U High).
- Optional Extended Operating Temperature Range.
- cULus, TUV and CE Marked (800W models only).
- AC/Power Good LED Display.
- Internal Oring Diodes Provided.

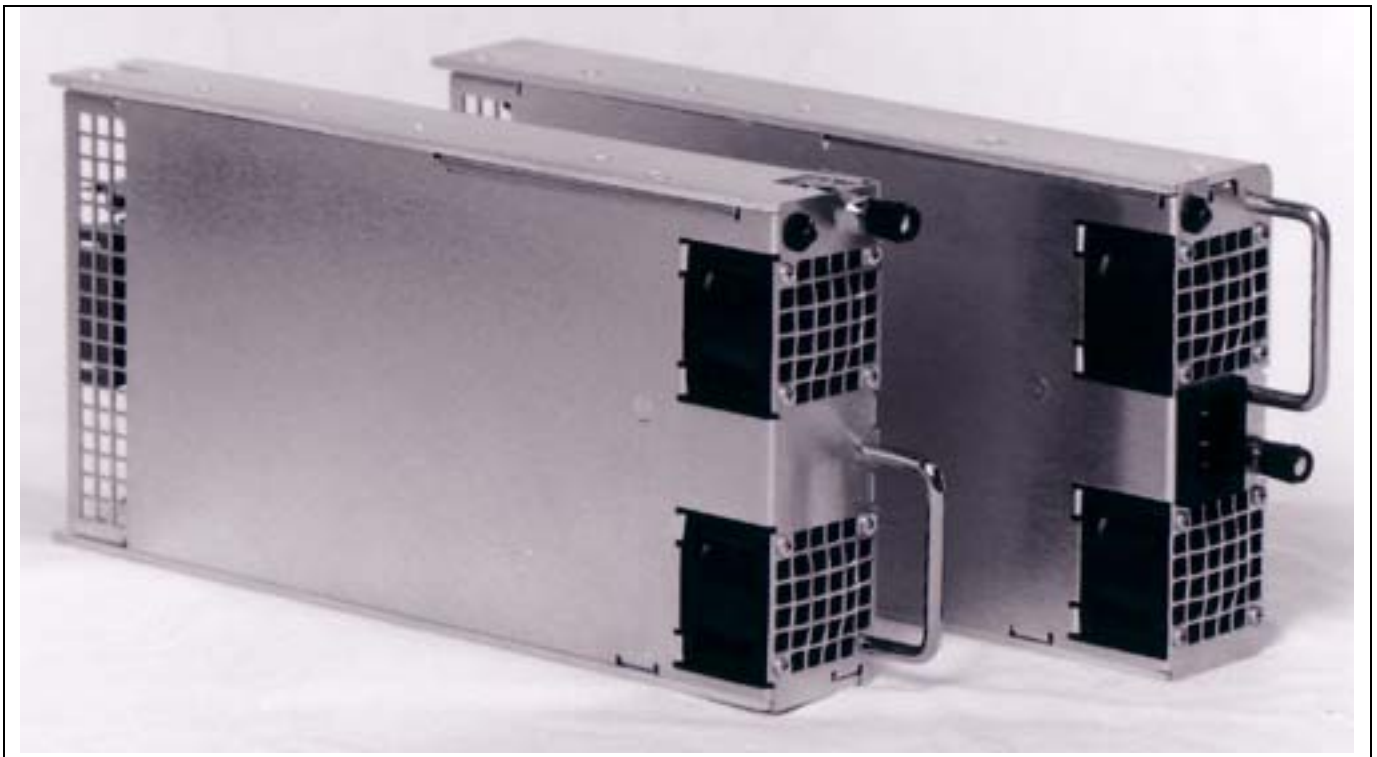

## General Product Specifications:

# HML801 Model Series

## 650W and 800W Single Output

### -INPUT-

Voltage/Current .....	AC 90-264V, 47-63Hz, 1 Phase. <u>800W</u> : 11.0A max; <u>650W</u> : 9.0A max.
Fusing .....	AC 15.0A, 250V internal line fuse provided, non-user serviceable.
Power Factor .....	>0.99 line PFC typical at AC 115V, full load.
Inrush Current .....	Thermistor soft start (~25°C cold start). 30Apk @ AC 115V, 60Apk @ AC 230V.
Transient Protection .....	MOV. Withstands transients as specified by EN61000-4-5 (differential and common mode).
Under Voltage Protection .....	Auto DC output shutdown when AC input falls below safe operating limits ( $\approx$ 80V AC). Automatic recovery.
EMI Filtering .....	Meets FCC Level A, and EN 55022 Level A.
Efficiency .....	75% typical at AC 115V, full load.
Redundant/Hot Swap .....	Full power N+1 redundant, hot swap capable.

### -OUTPUTS-

Voltage/Current (V/A) .....	V1
<b>HML651-2</b>	12.0V, 54.2A.
<b>HML801-5</b>	24.0V, 33.3A.
<b>HML801-6</b>	28.0V, 28.6A.
<b>HML801-8</b>	48.0V, 16.7A.
<b>HML801-9</b>	54.0V, 14.8A.

HML801: Total loading not to exceed 800 Watts at 50°C, or 400 Watts at 70°C. See Op. Temp. Specifications.

Output Voltage Setpoint .	Factory preset within $\pm$ 0.5% of nominal voltage.
Line/Load Regulation .....	$<\pm$ 1% at the sense point over full AC input range and 0 – 100% output loading, with sense leads connected.
Minimum Loading .....	None required.
Stability .....	Output drift $<\pm$ 0.2% after 20 minute warm-up.
Temp. Coefficient .....	$<\pm$ 0.02%/°C, 0° - 50°C, after 20 minute warm-up.
Dynamic Response .....	Less than 3% deviation with a 25% load change at 1A/ $\mu$ sec. Output recovers to within 1% in less than 300 $\mu$ sec.
Ripple and Noise (PARD) .....	$<$ 1% nominal with a 20 MHz bandwidth limit, measured with a 0.1 $\mu$ F ceramic capacitor in parallel with a 20 $\mu$ F tantalum capacitor connected between the measured output and its return at the connector.
Current Sharing/ Parallel N+1 Operation .....	Single wire connection for $\pm$ 10% current sharing between any number of units.
Remote Sense .....	Output compensates for up to 0.25V total line drop in the load cables. Output is internally sensed if leads are opened.
Output Turn-on Delay .....	$<$ 1sec from AC turn-on. $<$ 100msec from remote enable.
Over/Under Shoot .....	None at turn-on or turn-off.
Hold-Up Time .....	Output remains in regulation $>$ 15msec minimum following loss of AC power at low line, full load.

Over Current/Short Circuit Protection .....	Standard hiccup (cycles on/off) current limit when output current is 105% to 120% of full load.
Over Temperature Protection .....	Internal temperature sensing. Causes output to shut down. Automatic recovery.
Over Voltage Protection .....	Non-crowbar type. V-out exceeding 25% $\pm$ 10% of nominal will cause output to latch off. Remote enable or AC input recycle required to reset.

### -SIGNALS, INDICATORS and CONTROLS-

Remote Enable .....	Enabled by closed circuit or TTL logic 0. Disabled by open circuit or TTL logic 1.
Remote Adjust .....	External 0-5V DC on remote adjust pin referenced to negative sense equals -5% to +5% change of nominal output voltage.
Power Good (DC-OK) Signal .....	High signal when V-out is above 97% of nominal voltage. Signal goes low when V-out drops below 95% of nominal.
Power Fail Warning .....	Loss of input AC causes a TTL compatible signal to go low $>$ 4msec prior to any output dropping out of regulation. At AC turn-on, signal stays low until output is in regulation.
Under Voltage Warning ..	Output dropping below 95% of nominal triggers the power fail warning signal.
LED Indicator .....	Front panel mounted, single-color LED. Green indicates AC power ON and output within regulation. Off indicates an input and/or output fault.
AC On/Off Switch .....	<u>Optional</u> . Single pole, rocker type, on the front panel. Rocker face marked "I O". See option "O" in model configuration codes below. <i>Not available in combination with optional IEC AC inlet.</i>

### -OPERATING ENVIRONMENT-

Operating Temperature ..	Extended range: -40° – +50°C ambient at full load, with specified airflow. Full load start-up @-40°. Above 50°C, output derates linearly to 50% at 70°C.
Cooling .....	Front panel mounted, dual DC ball bearing fans provided, rated 13 cfm minimum each. Forward airflow direction is front to rear.
Relative Humidity .....	Up to 90% RH, non-condensing.
Operational Vibration .....	0.75G peak, 5 – 500Hz along three orthogonal axis.
Storage Temperature .....	-40° to 85°C.
Altitude .....	Operating to 10,000 ft. Storage to 30,000 ft.
MTBF .....	Designed for 150,000 hrs at 25°C.

## -INTERCONNECT-

Input/Output Connector..... 18-circuit (3X6), sequential contact, hot plug-gable type, located on the rear panel. Positronic Ind. P/N PLC18M4BN0A2-164.10. Mates with PI P/N PLC18F300A1 or equivalent.  
**Note:** Use of the specified mating connector is required to insure proper "make/break" sequential contact sequence.

AC Inlet Connector ..... Optional. Recessed 3-circuit, IEC 320/C14 type. User accessible on the front panel. See option "I" in the model configuration codes below. *Not available in combination with optional On/Off switch, or with AC input via the "hot plug".*

## -MECHANICAL-

(Refer to JE Outline Configuration Dwg, P/N 02951-000.)

Weight ..... 1.8kg [≈ 4.0lb].

Retaining Latch ..... Adjustable grip latch. User accessible on the front panel. Rotation of latch knob extends an arm down then forward into a user provided opening in the equipment to secure.

Mounting Orientation..... Add "H" at end of model code to designate horizontal (5.20"w x 1.60"h) or "V" for vertical (5.20"h x 1.60"w) installation.

## -SAFETY-

HML801 Models Only..... Recognized to U.S. and Canadian Bi-National Standard CSA C22.2 No. 60950 / UL 60950, Third (3<sup>rd</sup>) Edition (cULus); TUV approved to TUV EN60950/A1-A4/A11. CE marked.

## Input/Output and Signal Connector Type and Pin

### Functions:

Positronics Ind. P/N PLC18M4BN0. 18 circuit (3x6) hot plug-gable type, with 16ga contact pin terminals. Glass filled polyester insulator material, rated 94V-0. Secured in the unit rear. Use of Positronic PLC18F series mating connector is required to ensure correct mating contact sequence and current capacity.

<u>Pin#</u>	<u>Sequence</u>	<u>Function</u>
1	(2) standard,	Remote Voltage Adjust.
2	(2) standard,	Power Fail Warning.
3	(1) postmate,	Current Share Signal.
4	(2) standard,	No Connection.
5	Blank	Not Used.
6	(2) standard,	L – Line (AC) Input. No connection on models with optional IEC AC input connector.
7	(2) standard,	+S1 (+V1) Remote Sense.
8	(2) standard,	DC-OK Signal.
9	(2) standard,	–S1 (–V1) Remote Sense.
10	(3) postmate,	Remote DC Enable. TTL Low/Closed= ON.
11	(1) premate,	Primary Earth (PE) chassis ground.
12	Blank	Not Used.
13,14	(2) standard,	+V1 (DC power output).
15	(1) premate,	–V1 (Rtn).
16	(2) standard,	–V1 (Rtn).
17	Blank	Not Used.
18	(2) standard,	N – Neutral (ACC) Input. No connection on models with optional IEC AC input connector.

## CONFIGURATION OPTIONS:

### HOW TO USE THE TABLE:

A two, three or four character code is required following the base model description to define the desired model configuration. The codes are added in this sequence. Please choose one from each of the categories. User selection of options I or O will incur a slight additional unit cost. Please consult the factory for additional information.

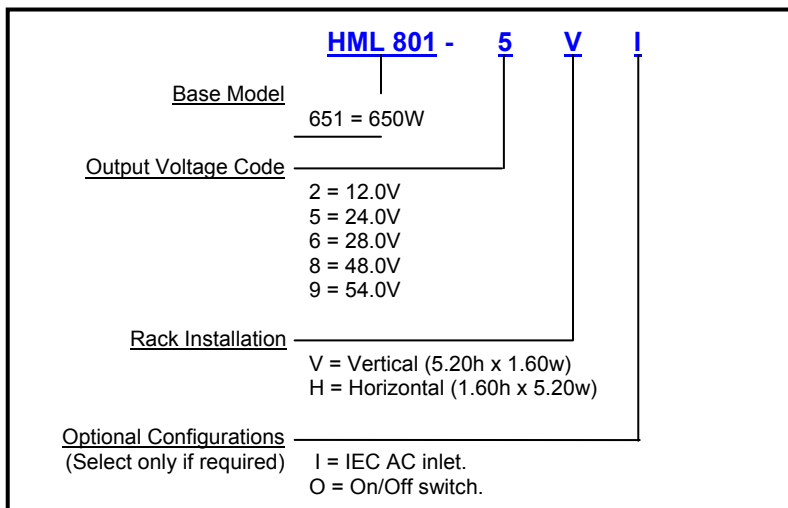

**HML801 MECHANICAL SPECIFICATIONS:**

